

LEAD-FREE COPPER ALLOY BALL

3-PIECE BODY

Full Port • Blowout Proof 316SS Stem • 316SS/Vented Ball • PTFE Seats

*NSF/ANSI 61-G & NSF/ANSI 372

CODE #862M (AK3TMMN) THREADED (½"-2")

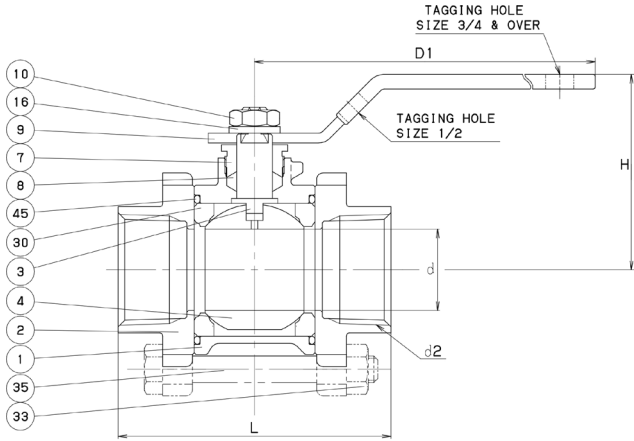

CODE #863M† (C3TMMN) SOLDER (½"-2")

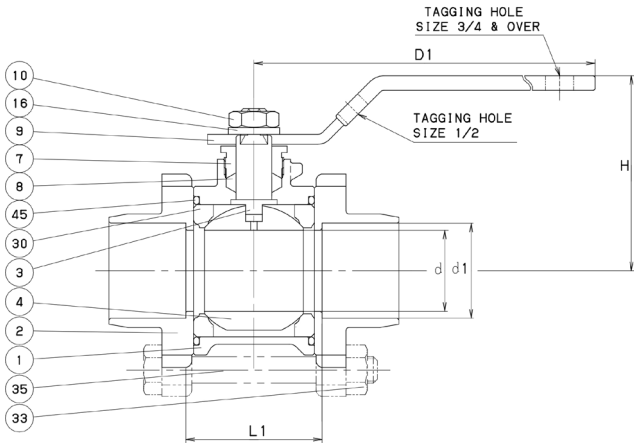

STANDARDS

END TO END	KITZ STD.
THREADED ENDS	ASME B1.20.1
SOLDER ENDS	ASME B16.18†
WALL THICKNESS	KITZ STD.
DESIGN	MSS SP-110

PRESSURE - TEMPERATURE

600 PSI - NON-SHOCK COLD WORKING PRESSURE (CWP)†
325 PSI at 212°F NON-SHOCK

MATERIAL LIST

NO.	NAME OF PART	SPECIFICATION
1	BODY	LF FORGED BRASS (C46750)
2	CAP	LF FORGED BRASS (C46750)
3	STEM	STAINLESS STEEL (316)
4	BALL (Vented)	STAINLESS STEEL (316)
7	GLAND	BRASS ROD (B16)
8	GLAND PACKING	PTFE
9	HANDLE	(1) CARBON STEEL
10	HANDLE NUT	CARBON STEEL
16	SPRING WASHER	CARBON STEEL
30	BALL SEAT	PTFE
33	CAP NUT	CARBON STEEL (A307 Gr. B)
35	CAP BOLT	CARBON STEEL (A307 Gr. B)
45	O-RING	FKM

NOTES:

- (1) ELECTROPLATED COATING OF ZINC AND PLASTIC COVERING
† P-T LIMITS FOR SOLDER JOINT VALVES PER ASME B16.18

DIMENSIONS & WEIGHTS

SIZE d2	d	H	D1	L	L1	d1		Wt. Lb/Kg	Crtn Qty	
						Max	Min			
in mm	½	0.59	1.65	3.23	2.40	1.40	0.631	0.627	1.0	36
		15.0	42.0	82.0	61.0	35.6	16.0	15.9	0.45	
in mm	¾	0.79	2.01	3.94	2.76	1.37	0.881	0.877	1.0	24
		20.1	51.0	100.1	70.1	34.8	22.4	22.3	0.45	
in mm	1	0.98	2.32	5.12	3.27	1.64	1.132	1.128	2.0	16
		24.9	59.0	130.0	83.1	41.7	28.8	28.7	0.9	
in mm	1¼	1.26	2.52	5.12	3.90	1.96	1.382	1.378	4	8
		32.0	64.0	130.0	99.1	49.8	35.1	35.0	1.81	
in mm	1½	1.57	2.87	5.91	4.61	2.43	1.633	1.628	7	6
		39.9	73.0	150.1	117.1	61.7	41.5	41.4	3.18	
in mm	2	1.97	3.15	5.91	5.47	2.79	2.133	2.128	11.0	4
		50.0	80.0	150.1	138.9	70.9	54.2	54.1	4.99	



Certified to
NSF/ANSI 61-G

*Product complies with NSF/ANSI Standard 61 Annex G, NSF/ANSI Standard 372 and conforms with lead content requirements for "lead free" plumbing as defined by California, Vermont, Maryland, and Louisiana state laws and the U.S. Safe Drinking Water Act that went into effect January 2014.