

# GLOBE

## CLASS 125 CAST IRON

Outside Screw & Yoke • Bolted Bonnet  
Bronze Mounted • Beveled Wedge Disc

**CODE # 76 (125FCJ)**

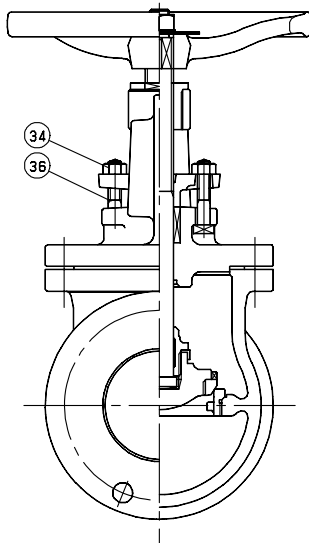
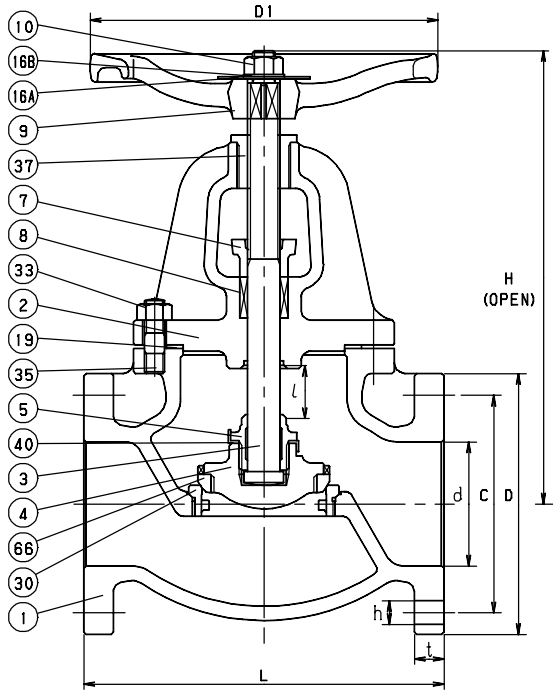

STANDARDS	
END TO END	ANSI B16.10, CLASS 125
END CONNECTION	ANSI B16.1, CLASS 125
DESIGN	MSS SP-85, TYPE I
MILITARY	MSS SP-85, TYPE I

PRESSURE/TEMPERATURE	
125 PSI - SATURATED STEAM TO 353°F	
- FLUID TO 406°F	
200 PSI NON-SHOCK COLD WATER, OIL OR GAS	

MATERIAL LIST		
NO.	NAME OF PART	SPECIFICATION
1	BODY	CAST IRON (A126 CLASS B)
2	BONNET	CAST IRON (A126 CLASS B)
3	STEM	FORGED BRASS (B124, C37700)
4	DISC (2)	CAST BRONZE (B62)
	(2 1/2 - 8)	CAST IRON (A126 CLASS B)
5	LOCK NUT	CAST BRONZE (B62)
7	GLAND	DUCTILE IRON (A395)
8	GLAND PACKING	NON-ASBESTOS PACKING
9	HAND WHEEL (2 - 6)	CAST IRON (A126 CLASS B)
	(8)	DUCTILE IRON (A536)
10	WHEEL NUT	CARBON STEEL (A307 Gr. B)
16A	NAME PLATE	ALUMINUM
19	GASKET	NON ASBESTOS SHEET
30	BODY SEAT RING	CAST BRONZE (B62)
33	BONNET NUT	CARBON STEEL (A307 Gr. B)
34	GLAND NUT	CARBON STEEL (A307 Gr. B)
35	BONNET BOLT	CARBON STEEL (A307 Gr. B)
36	GLAND BOLT	CARBON STEEL (A307 Gr. B)
37	YOKE BUSH	CAST BRONZE (B62)
40	LOCK PLATE	STAINLESS STEEL (A167, TYPE 304)
66	DISC SEAT RING	CAST BRONZE (B62)

DIMENSIONS - WEIGHTS - QUANTITIES												
d2 SIZE	d	H	D1	L	l	D	BOLT HOLE			t	APPROX. NET WT.	
							C	No.	h			
2	1.97	10.91	7.09	8.00	.79	6.00	4.75	4	.75	5/8	.62	30
2 1/2	2.56	12.09	7.09	8.50	1.02	7.00	5.50	4	.75	5/8	.69	46
3	3.15	13.90	8.86	9.50	1.18	7.50	6.00	4	.75	5/8	.75	66
4	3.94	15.91	11.02	11.50	1.50	9.00	7.50	8	.75	5/8	.94	92
5	4.92	17.87	11.81	13.00	1.81	10.00	8.50	8	.88	3/4	.94	141
6	5.91	20.98	13.78	14.00	2.28	11.00	9.50	8	.88	3/4	1.00	197
8	7.87	25.28	17.72	19.50	2.91	13.50	11.75	8	.88	3/4	1.12	323

CAST IRON GATE