

FORGED BRASS BALL VALVE

SINGLE UNION

Two Piece Body • Full Port

Blowout Proof Stem • Chrome Plated Ball • PTFE Seats and Seals

CODE # 68U (AKTAFU) THREADED

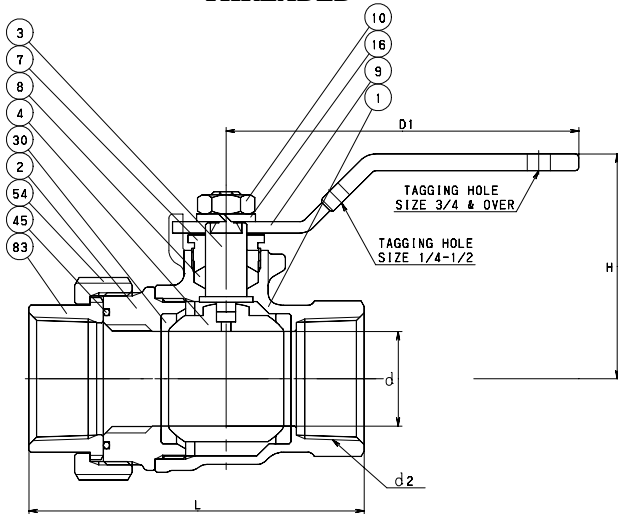

CODE # 69U (CTAFU) SOLDER*

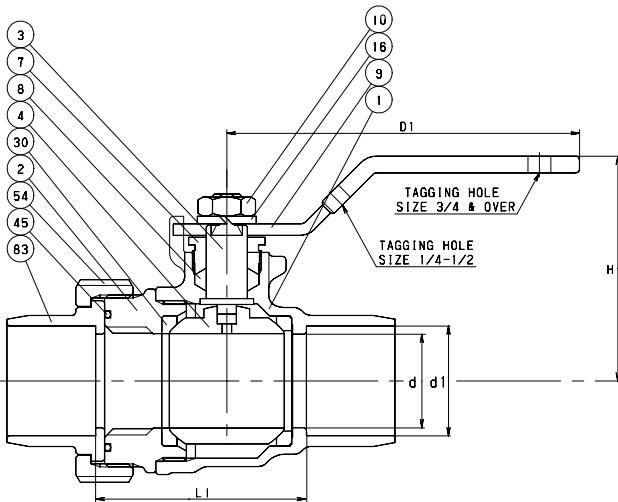

*REFERENCE VALVE INSTALLATION TIPS FOR SOUND SOLDER JOINTS (PAGE BV-66) OR SEE INSTALLATION SHEET PACKAGED WITH VALVE.

SPECIFICATION

Approved valve shall have two piece forged brass body and single union connection with FPM hand-tight o-ring seal, blowout proof stem, PTFE seats/seals, chrome plated ball, and full port design. Valves shall be pressure rated to 150 PSI @ 300°F/600 WOG and conform to MSS-SP 110.

KITZ Code No. 68U (AKTAFU) Threaded Ends
69U (CTAFU) Soldered Ends

STANDARDS

END TO END	KITZ
THREADED ENDS	ANSI B1.20.1
SOLDER JOINT ENDS	ANSI B16.18
WALL THICKNESS	KITZ
CONFORMS TO MSS-SP 110	

PRESSURE/TEMPERATURE

150 PSI @ 300°F
600 PSI NON-SHOCK COLD WATER, OIL OR GAS

NOTE: PRESSURE/TEMPERATURE CHART - PAGE BV-29

MATERIAL LIST

NO.	NAME OF PART	SPECIFICATION
1	BODY	FORGED BRASS (B283, C37700)
2	BODY CAP	FORGED BRASS (B283, C37700)
3	STEM	(1) SPECIAL BRASS (KITZ "K-METAL")
4	BALL	(2) FORGED BRASS (B283, C37700)
7	GLAND	BRASS ROD (B16)
8	GLAND PACKING	PTFE
9	HANDLE	(3) CARBON STEEL
10	HANDLE NUT	CARBON STEEL
16	SPRING WASHER	CARBON STEEL
30	BALL SEAT	PTFE
45	O-RING	FPM
54	UNION NUT	FORGED BRASS (B283, C37700)
83	UNION NIPPLE	FORGED BRASS (B283, C37700)

NOTES: (1) PROPRIETARY DEZINCIFICATION RESISTANT MATERIAL.
(2) CR. PLATING
(3) ELECTROPLATED ZINC WITH PLASTIC COVERING

DIMENSIONS - WEIGHTS - QUANTITIES

d2 SIZE	d	H	D1	L	L1	d1		APPROX. CARTON NET WT.	QTY
						Max.	Min.		
1/4	.39	1.54	3.23	2.05	-	-	-	50	120
3/8	.39	1.54	3.23	2.05	1.37	.506	.502	50	120
1/2	.59	1.65	3.23	2.48	1.52	.631	.627	60	96
3/4	.79	2.01	3.94	2.95	1.89	.881	.877	66	60
1	.98	2.32	5.12	3.46	2.20	1.132	1.128	60	36
1 1/4	1.26	2.52	5.12	3.86	2.59	1.382	1.378	60	24
1 1/2	1.57	2.87	5.91	4.45	3.10	1.633	1.628	61	16
2	1.97	3.15	5.91	4.96	3.58	2.133	2.128	87	16